

Integrated design, save space



Front view



Left side view



oblique view



back view

Mechanical structure

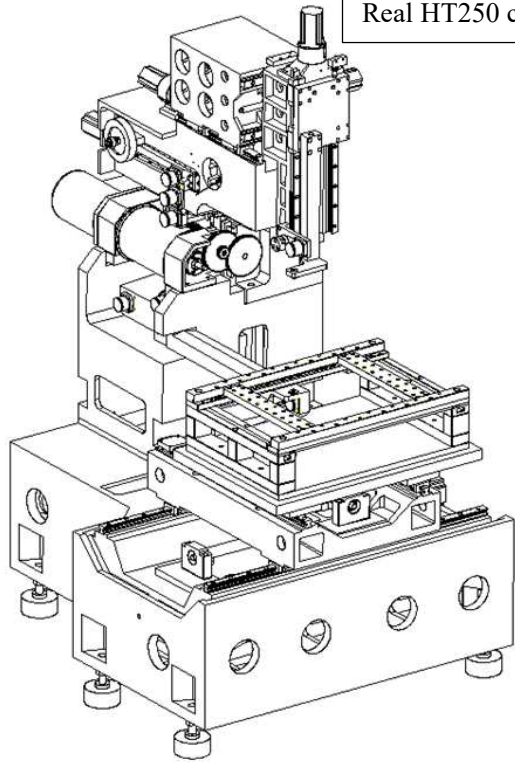

Real HT250 casting, three times tempering

High rigidity "C" structure



Actual view of mechanical structure

"T" Shape machine bed

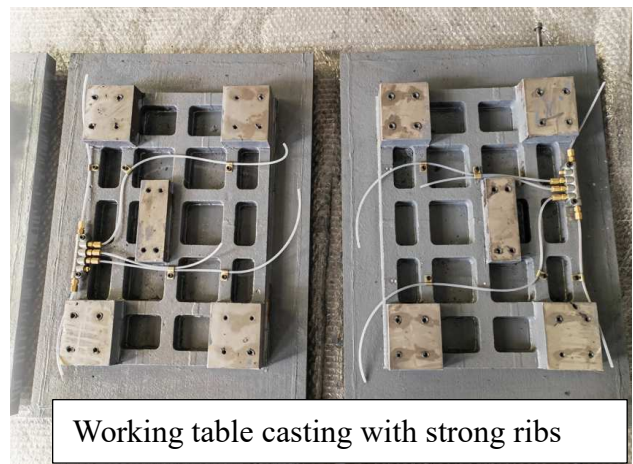

Working table casting with strong ribs

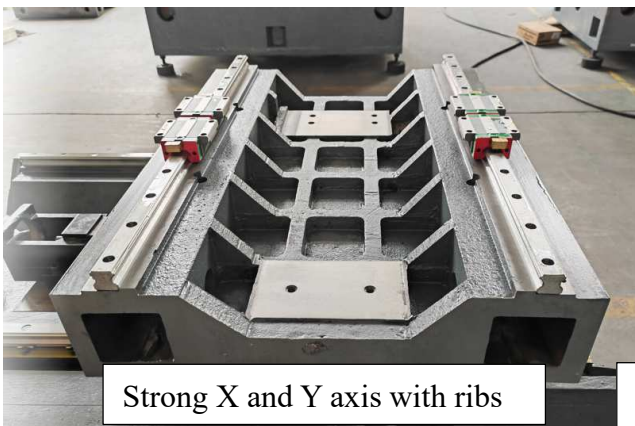

Strong X and Y axis with ribs

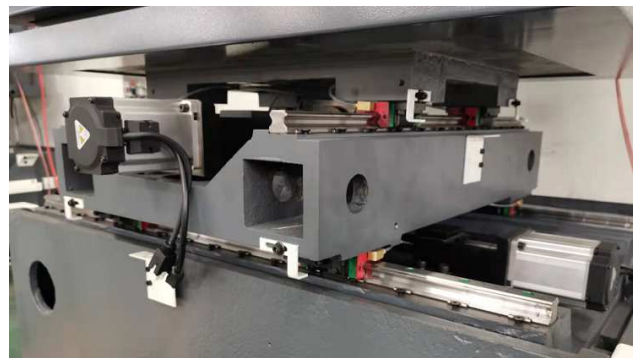

Strong structure, about 900kg heavier than competitors



HIWIN “P” grade linear guideway for guide for X,Y,U,V and “H” grade for Z axis



“P” grade ball screw



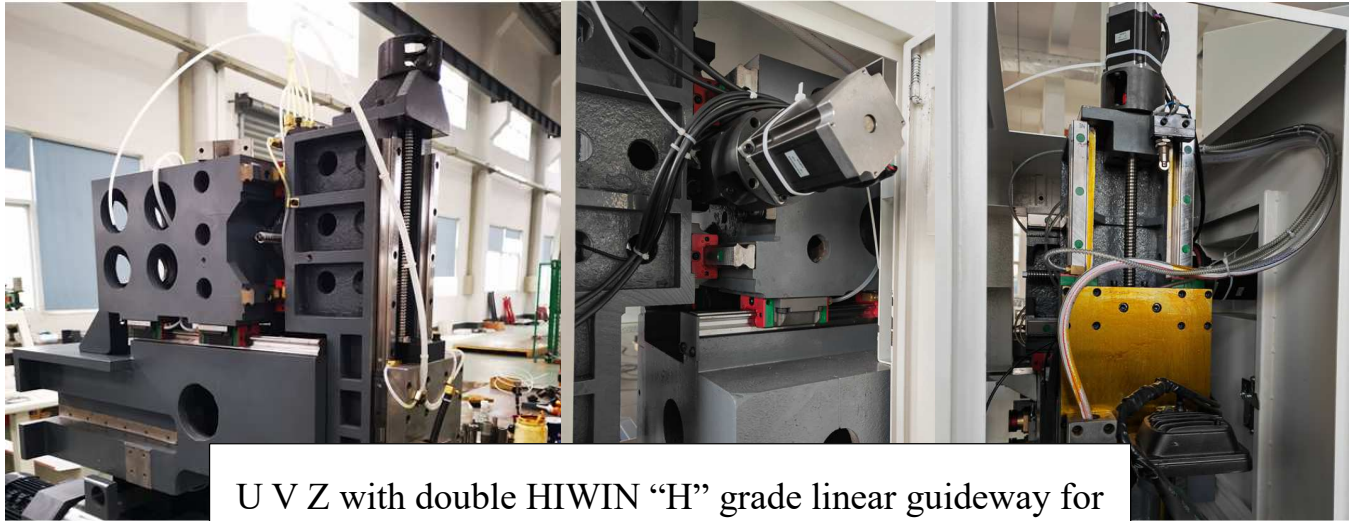

U V Z with double HIWIN "H" grade linear guideway for

Fixed wire drum at left side, touch screen control



Touch screen wire drum control

PLC controlled Automatic wire tightening

Fixed wire drum

Wire tightening and tensioner motor

absolute value AC Servo motor of wire drum



Wire drum motion control system, touch screen, much easier to use

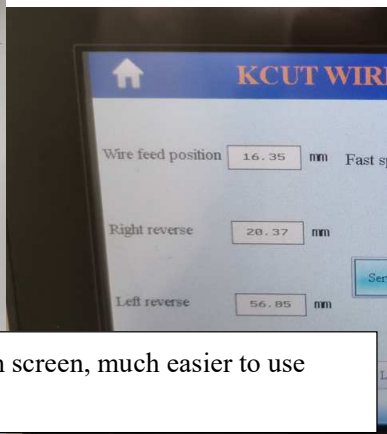

Control cabinet, PLC control, simplified and reliable

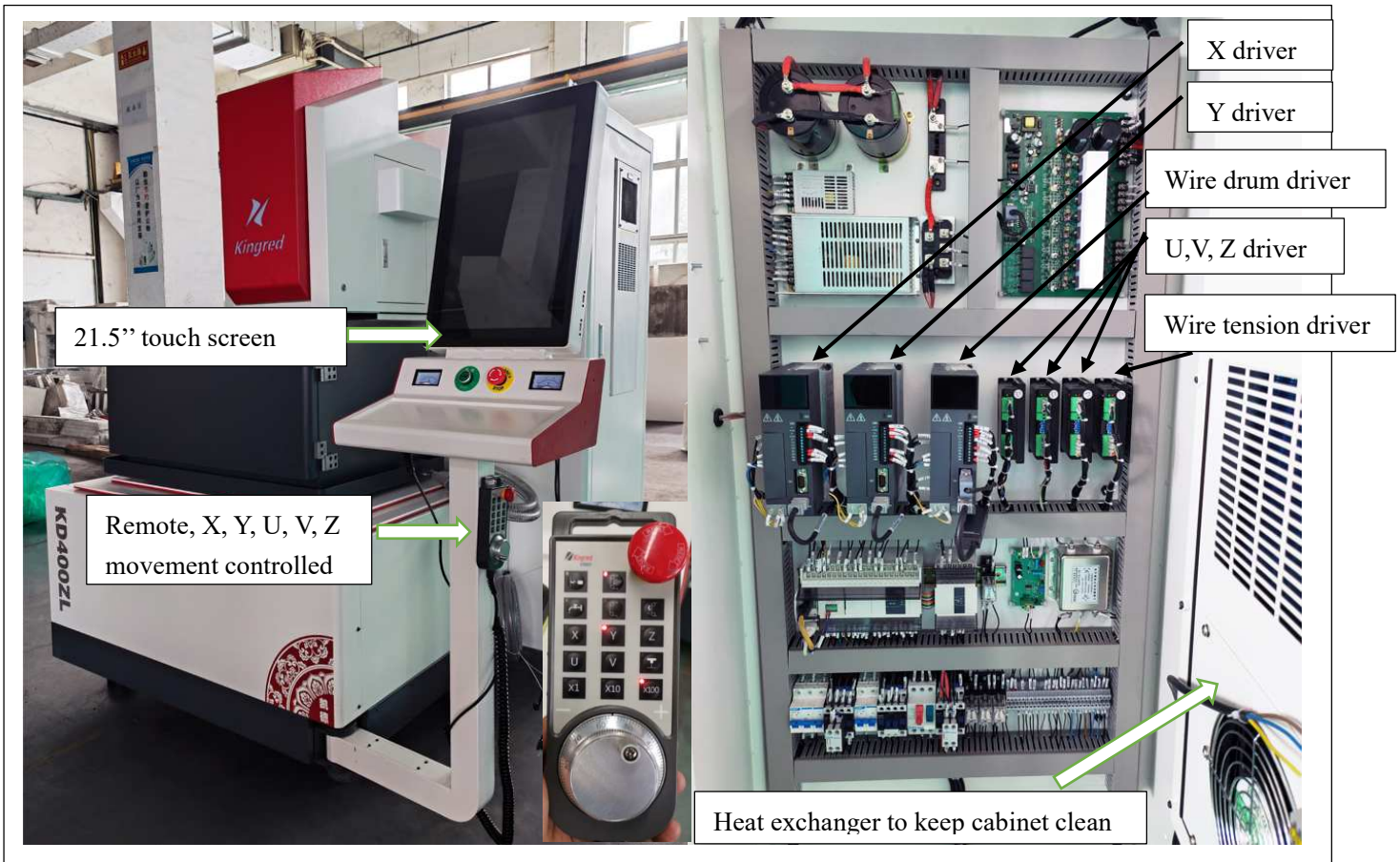

Powerful control system

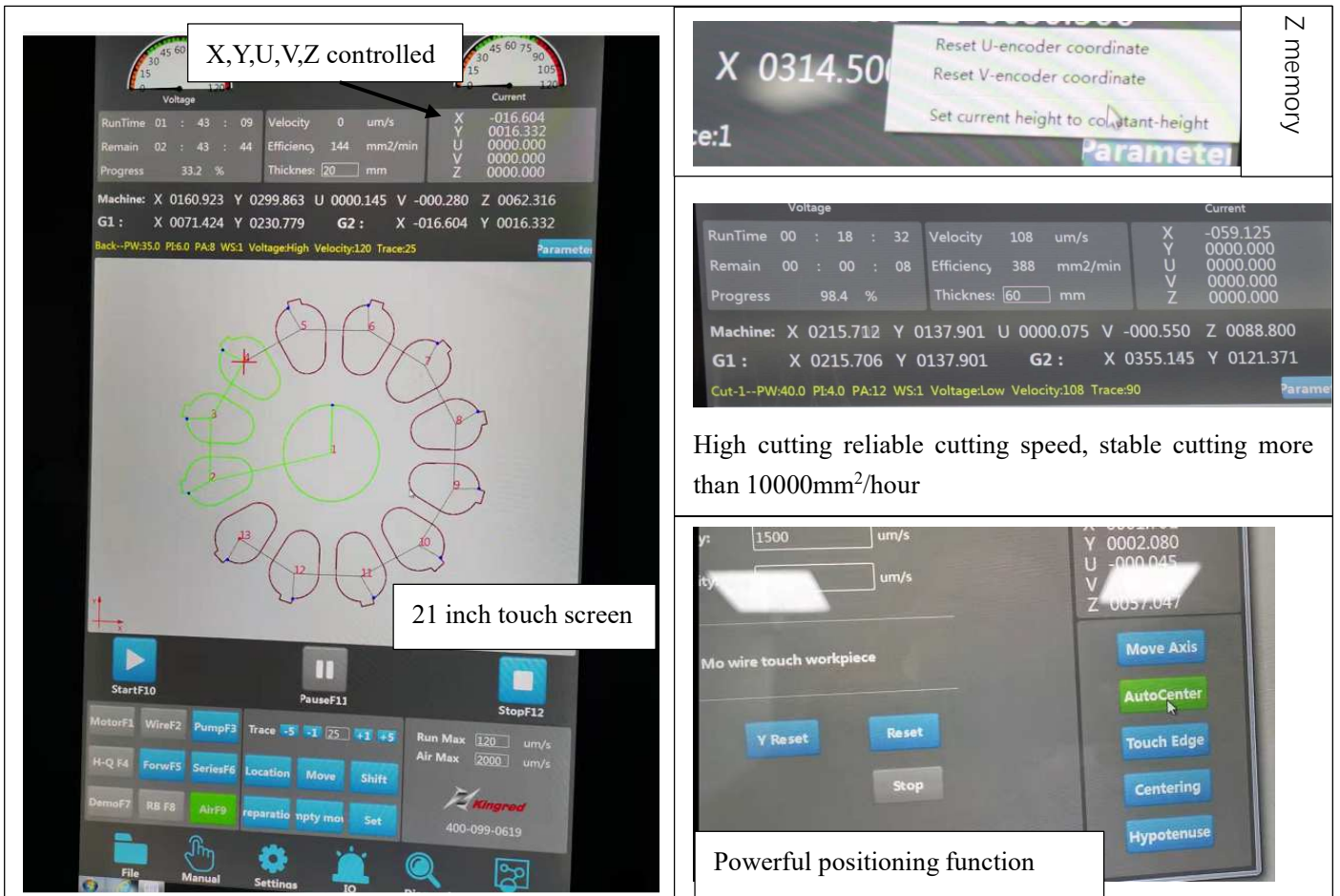



Logitech wireless keyboard and mouse



Three-color working condition light



Backside view

Windows 7/Windows 10 high configuration touch screen computer

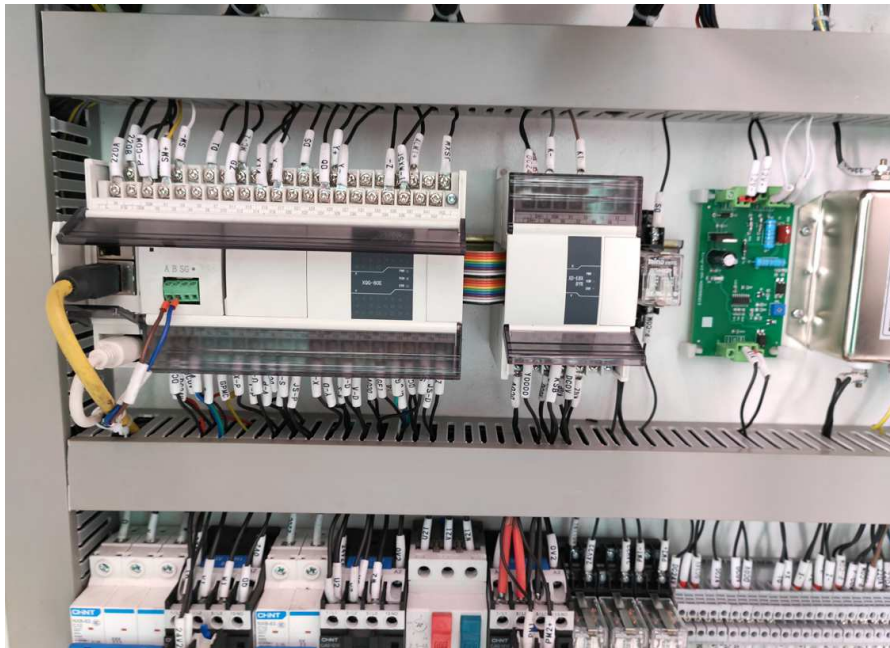

KCUT PLC control, communication with Internet protocol, super-fast speed, and good anti-interference capacity.



Heat exchange to keep cabinet clean and reliability

HIWIN Linear guideway for all X,Y,U,V,Z, wire drum and wire tension.

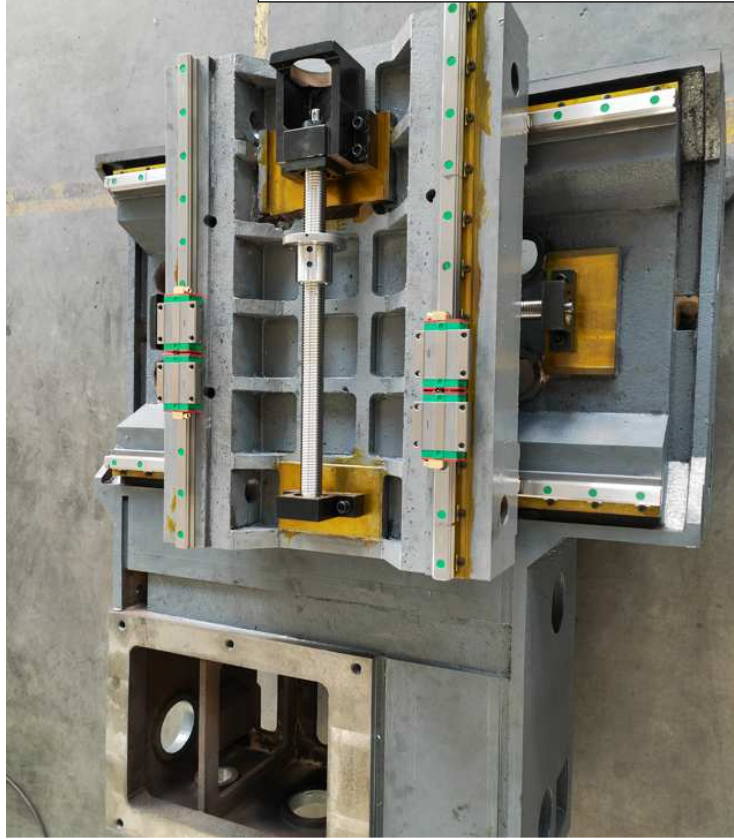

vacuum packaging and plywood case for export